

ETHERNET TRANSCEIVER

FEATURES

- 0.6- to 1.3-Gigabits Per Second (Gbps) Serializer/Deserializer
- Low Power Consumption 250 mW (typ) at 1.25 Gbps
- LVPECL-Compatible Differential I/O on High-Speed Interface
- Single Monolithic PLL Design
- Support For 10-Bit Interface
- Fast Relock Times Less Than 256 ns (typ) Suitable for EPON/GEPON Applications such as OLT and ONU Systems
- Receiver Differential-Input Thresholds, 200-mV Minimum
- Industrial Temperature Range From -40°C to 85°C
- IEEE 802.3 Gigabit Ethernet Compliant
- Designed in $0.25\ \mu\text{m}$ CMOS Technology
- No External Filter Capacitors Required
- Comprehensive Suite of Built-In Testability
- 2.5-V Supply Voltage for Lowest-Power Operation
- 3.3-V Tolerant on LVTTTL Inputs
- Hot Plug Protection
- 40-Pin 6-mm \times 6-mm QFN PowerPAD™ Package

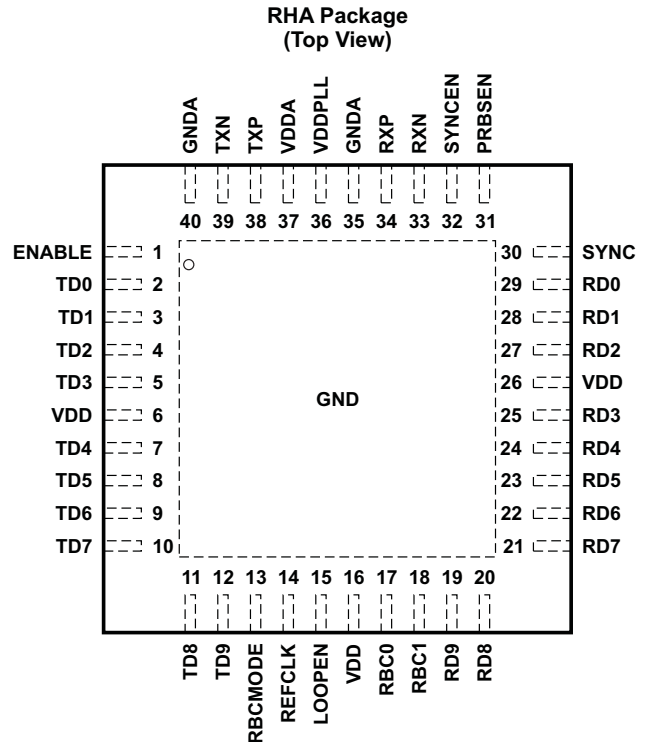

DESCRIPTION

The TLK1221 gigabit Ethernet transceiver provides for high-speed full-duplex point-to-point data transmissions. These devices are based on the timing requirements of the 10-bit interface specification by the IEEE 802.3 Gigabit Ethernet specification. The TLK1221 supports data rates from 0.6 Gbps through 1.3 Gbps.

The primary application of these devices is to provide building blocks for point-to-point baseband data transmission over controlled-impedance media of $50\ \Omega$. The transmission media can be printed-circuit board traces, copper cables or fiber-optical media. The ultimate rate and distance of data transfer is dependent upon the attenuation characteristics of the media and the noise coupling to the environment.

The TLK1221 performs the data serialization, deserialization, and clock extraction functions for a physical layer interface device. The transceiver operates at 1.25 Gbps (typical), providing up to 1 Gbps of data bandwidth over a copper or optical media interface.



Please be aware that an important notice concerning availability, standard warranty, and use in critical applications of Texas Instruments semiconductor products and disclaimers thereto appears at the end of this data sheet.

PowerPAD is a trademark of Texas Instruments.
All other trademarks are the property of their respective owners.



These devices have limited built-in ESD protection. The leads should be shorted together or the device placed in conductive foam during storage or handling to prevent electrostatic damage to the MOS gates.

DESCRIPTION (CONTINUED)

This device supports the defined 10-bit interface (TBI). In the TBI mode, the serializer/deserializer (SERDES) accepts 10-bit wide 8b/10b parallel encoded data bytes. The parallel data bytes are serialized and transmitted differentially at PECL-compatible voltage levels. The SERDES extracts clock information from the input serial stream and deserializes the data, outputting a parallel 10-bit data byte.

A comprehensive series of built-in tests is provided for self-test purposes, including loopback and pseudorandom binary sequence (PRBS) generation and verification.

The TLK1221 is housed in a high-performance, thermally enhanced, 40-pin QFN package. Use of this package does not require any special considerations except to note that the pad, which is an exposed die pad on the bottom of the device, is a metallic thermal and electrical conductor. It is required that the TLK1221 pad be soldered to the thermal land on the board as it serves as the main ground connection for the device.

The TLK1221 is characterized for operation from -40°C to 85°C .

This device uses a 2.5-V supply. The I/O section is 3.3-V compatible. With the 2.5-V supply, the chipset is very power-efficient, dissipating less than 200 mW typical power when operating at 1.25 Gbps.

The TLK1221 is designed to be hot-plug capable. A power-on reset causes RBC0, RBC1, the parallel output signal terminals, TXP, and TXN to be held in the high-impedance state.

Differences Between TLK2201B, TLK2201BI, TLK1221, and TNETE2201

The TLK1221 is the functional equivalent of the TNETE2201. There are several differences between the devices as noted below. See [Figure 12](#) in the application information section for an example of a typical application circuit.

- V_{CC} is 2.5 V for the TLK2201B, TLK2201BI, TLK1221, and TLK1201A vs 3.3 V for TNETE2201.
- The PLL filter capacitors on pins 16, 17, 48, and 49 of the TNETE2201 are no longer required. The TLK2201B, TLK2201BI, TLK1221, and TLK1201A use these pins to provide added test capabilities. The capacitors, if present, do not affect the operation of the device.
- No pulldown resistors are required on the TXP/TXN outputs.
- The TLK1221 is a QFN version of the TLK1211 optimized for TBI-mode operation with no JTAG functionality.
- TLK1221 also has a faster relock time than TLK1201A or TLK2201B.

FUNCTIONAL BLOCK DIAGRAM

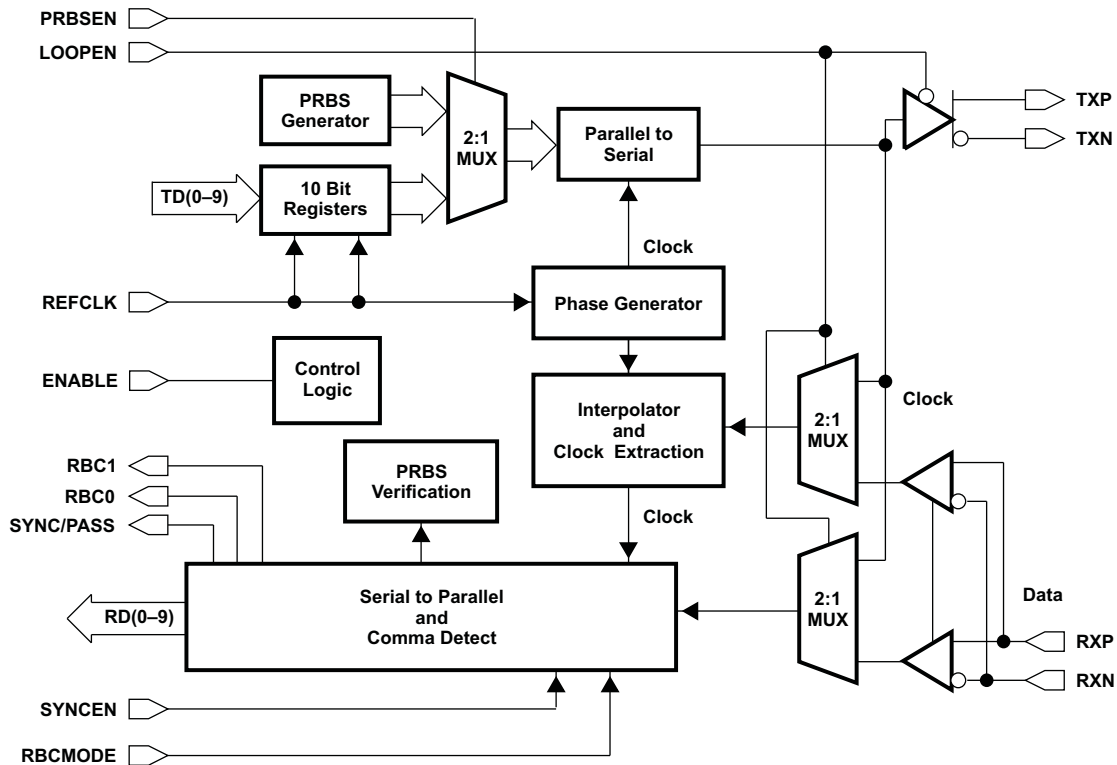

Detailed Description

In the TBI mode, the transmitter portion registers incoming 10-bit-wide data words (8b/10b encoded data, TD0–TD9) on the rising edge of REFCLK. REFCLK is also used by the serializer, which multiplies the clock by a factor of 10, providing a signal that is fed to the shift register. The 8b/10b encoded data is transmitted sequentially, bits 0 through 9, over the differential high-speed I/O channel.

Transmission Latency

Data transmission latency is defined as the delay from the initial 10-bit word load to the serial transmission of bit 9. The minimum latency in TBI mode is 19 bit times. The maximum latency in TBI mode is 20 bit times.

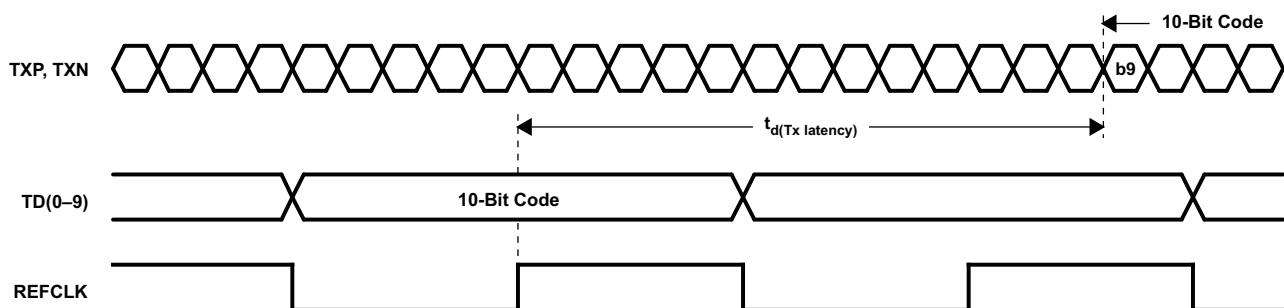

Figure 1. Transmitter Latency, Full-Rate Mode

Data Reception

The receiver section deserializes the differential serial data. The serial data is retimed based on an interpolated clock generated from the reference clock. The serial data is then aligned to the 10-bit word boundaries and presented to the protocol controller along with the receive byte clocks (RBC0, RBC1).

Receiver Clock Select Mode

The TLK1221 only supports TBI-mode operation with half-rate and full-rate clocks on RBC0 and RBC1. In TBI mode, there are two user-selectable clock modes that are controlled by the RBCMODE terminal: 1) full-rate clock on RBC0 and 2) half-rate clocks on RBC0 and RBC1.

Table 1. Mode Selection

RBCMODE	MODE	RECEIVE BYTE CLOCK
		TLK1221
0	TBI half-rate	30–65 MHz
1	TBI full-rate	60–130 MHz

In the half-rate mode, two receive byte clocks (RBC0 and RBC1) are 180 degrees out of phase and operate at one-half the data rate. The clocks are generated by dividing down the recovered clock. The received data is output with respect to the two receive byte clocks (RBC0, RBC1), allowing a protocol device to clock the parallel bytes using the RBC0 and RBC1 rising edges. For the outputs to the protocol device, byte 0 of the received data is valid on the rising edge of RBC1. Refer to the timing diagram shown in [Figure 2](#).

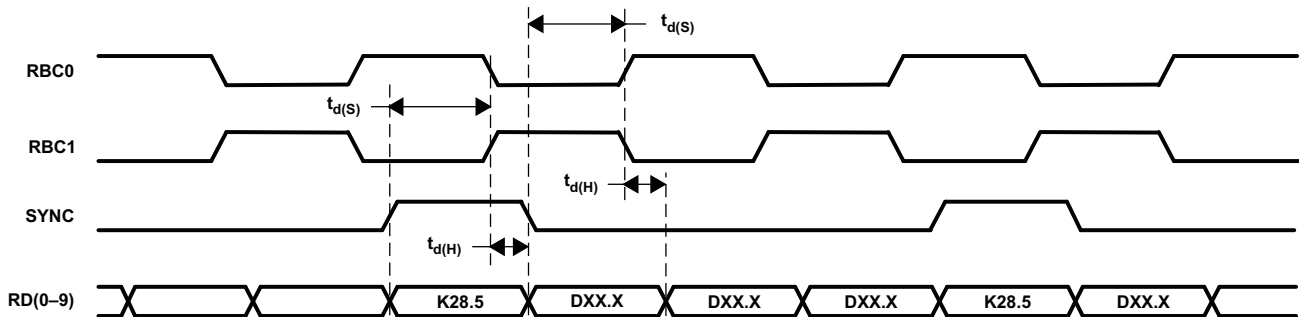

Figure 2. Synchronous Timing Characteristic Waveforms (TBI Half-Rate Mode)

The receiver clock interpolator can lock to the incoming data without the need for a lock-to-reference preset. The received serial data rate (RXP and RXN) is at the same baud rate as the transmitted data stream, $\pm 0.02\%$ (200 PPM) for proper operation.

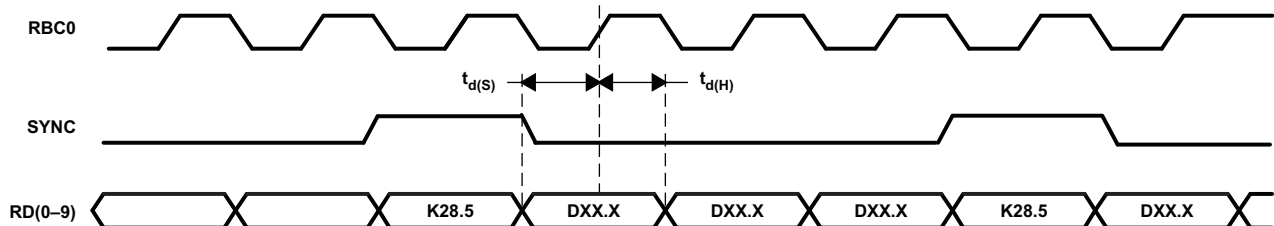

Figure 3. Synchronous Timing Characteristic Waveforms (TBI Full-Rate Mode)

Receiver Word Alignment

These devices use the IEEE 802.3 Gigabit Ethernet defined 10-bit K28.5 character, which contains the 7-bit comma-pattern word alignment scheme. The following sections explain how this scheme works and how it realigns to the proper byte boundary of the data.

Comma Character on Expected Boundary

These devices provide 10-bit K28.5 character recognition and word alignment. The 10-bit word alignment is enabled by forcing the SYNCEN terminal high. This enables the function that examines and compares serial input data to the 7-bit synchronization pattern. The K28.5 character is defined by the 8b/10b coding scheme as a pattern consisting of 0011 1110 10 (a negative number beginning with disparity), with the 7 MSBs (0011 111) referred to as the comma character. The K28.5 character was implemented specifically for aligning data words. As long as the K28.5 character falls within the expected 10-bit boundary, the received 10-bit data is properly aligned and data realignment is not required. Figure 2 shows the timing characteristics of RBC0, RBC1, SYNC and RD0–RD9 while synchronized. (Note: the K28.5 character is valid on the rising edge of RBC1).

Comma Character Not on Expected Boundary

If synchronization is enabled and a K28.5 character straddles the expected 10-bit word boundary, then word realignment is necessary. Realignment or shifting the 10-bit word boundary truncates the character following the misaligned K28.5, but the following K28.5 and all subsequent data is aligned properly as shown in Figure 4. The RBC0 and RBC1 pulse widths are stretched or stalled in their current state during realignment. With this design, the maximum stretch that occurs is 20 bit times. This occurs during a worst-case scenario when the K28.5 is aligned to the falling edge of RBC1 instead of the rising edge. Figure 4 shows the timing characteristics of the data realignment.

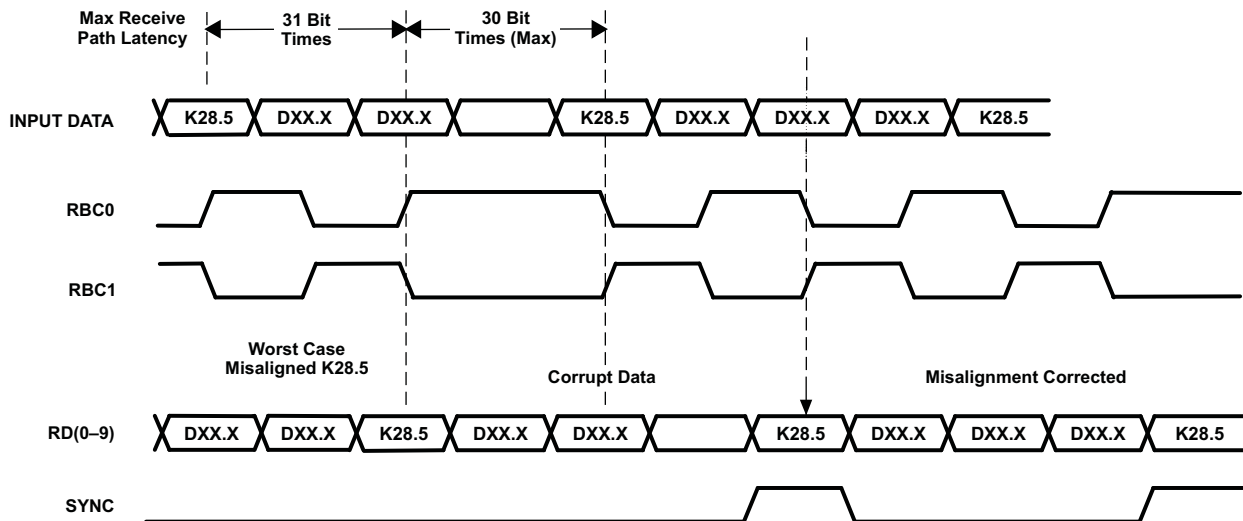

Figure 4. Word Realignment Timing Characteristic Waveforms

Systems that do not require framed data may disable byte alignment by tying SYNCEN low.

When a SYNC character is detected, the SYNC signal is brought high and is aligned with the K28.5 character. The duration of the SYNC pulse is equal to the duration of the data.

Data Reception Latency

The serial-to-parallel data latency is the time from when the first bit arrives at the receiver until it is output in the aligned parallel word with RD0 received as the first bit. The minimum latency in TBI mode is 21 bit times and the maximum latency is 31 bit times.

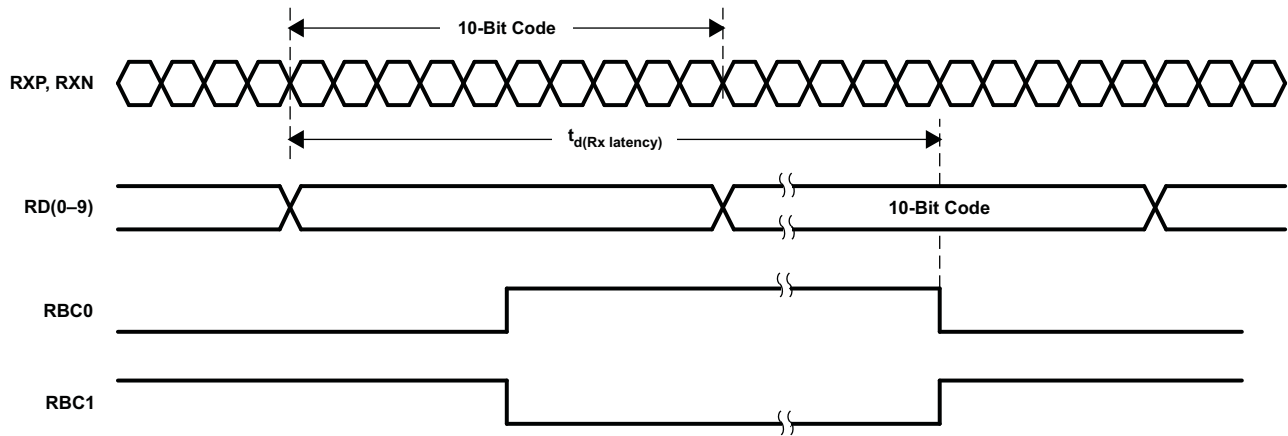

Figure 5. Receiver Latency, TBI Half-Rate Mode Shown

Testability

The loopback function provides for at-speed testing of the transmit/receive section of the circuitry. The enable function allows for all circuitry to be disabled so that an Iddq test can be performed. The PRBS function also allows for built-in self-test (BIST).

Loopback Testing

The transceiver can provide a self-test function by enabling (LOOPEN to high level) the internal loopback path. Enabling this function causes serial transmitted data to be routed internally to the receiver. The parallel data output can be compared to the parallel input data for functional verification. (The external differential output is held in a high-impedance state during the loopback testing.)

ENABLE Function

When held low, ENABLE disables all quiescent power in both analog and digital circuitry. This allows an ultralow-power idle state when the link is not active.

PRBS Function

These devices have a built-in $2^7 - 1$ PRBS function. When the PRBSEN control bit is set high, the PRBS test is enabled. A PRBS is generated and fed into the 10-bit parallel transmitter input bus. Data from the normal parallel input source is ignored during PRBS test mode. The PRBS pattern is then fed through the transmit circuitry as if it were normal data and sent out to the transmitter. The output can be sent to a bit error rate tester (BERT) or to the receiver of another TLK1221. Because the PRBS is not really random and is really a predetermined sequence of ones and zeros, the data can be captured and checked for errors by a BERT. These devices also have a built-in BERT function on the receiver side that is enabled by PRBSEN. It can receive a PRBS pattern and check for errors, and then report the errors by forcing the SYNC/PASS terminal low. The PRBS testing supports two modes (normal and latched), which are controlled by the SYNCEN input. When SYNCEN is low, the result of the PRBS bit-error-rate test is passed to the SYNC/PASS terminal. When SYNCEN is high, the result of the PRBS verification is latched on the SYNC/PASS output (i.e., a single failure forces SYNC/PASS to remain low).

Table 2. TERMINAL FUNCTIONS

TERMINAL		I/O	DESCRIPTION
NAME	NO.		
SIGNAL			
TXP TXN	38 39	PECL O	Differential output transmit. TXP and TXN are differential serial outputs that interface to a copper or an optical I/F module. TXP and TXN are put in a high-impedance state when LOOPEN is high and are active when LOOPEN is low.

Table 2. TERMINAL FUNCTIONS (continued)

TERMINAL		I/O	DESCRIPTION
NAME	NO.		
RXP RXN	34 33	PECL I	Differential input receive. RXP and RXN together are the differential serial input interface from a copper or an optical I/F module.
REFCLK	14	I	Reference clock. REFCLK is an external input clock that synchronizes the receiver and transmitter interface (60 MHz to 130 MHz). The transmitter uses this clock to register the input data (TD0–TD9) for serialization. In the TBI mode that data is registered on the rising edge of REFCLK.
TD0–TD9	2–5, 7–12	I	Transmit data. These inputs carry 10-bit parallel data output from a protocol device to the transceiver for serialization and transmission. This 10-bit parallel data is clocked into the transceiver on the rising edge of REFCLK and transmitted as a serial stream with TD0 sent as the first bit.
RD0–RD9	29–27, 25–19	O	Receive data. These outputs carry 10-bit parallel data output from the transceiver to the protocol layer. The data is referenced to terminals RBC0 and RBC1. RD0 is the first bit received.
RBC0 RBC1	17 18	O	Receive byte clock. RBC0 and RBC1 are recovered clocks used for synchronizing the 10-bit output data on RD0–RD9. In the half-rate mode, the 10-bit output data words are valid on the rising edges of RBC0 and RBC1. These clocks are adjusted to half-word boundaries in conjunction with synchronous detect. The clocks are always expanded during data realignment and never slivered or truncated. RBC0 registers bytes 1 and 3 of received data. RBC1 registers bytes 0 and 2 of received data. In normal-rate mode, only RBC0 is valid and operates at 1/10th the serial data rate. Data is aligned to the rising edge.
RBCMODE	13	I P/D ⁽¹⁾	Receive clock mode select. When RBCMODE is low, half-rate clocks are output on RBC0 and RBC1. When RBCMODE is high, a full baud-rate clock is output on RBC0, and RBC1 is held low.
SYNCEN	32	I P/U ⁽¹⁾	Synchronous function enable. When SYNCEN is high, the internal synchronization function is activated. When this function is activated, the transceiver detects the comma pattern (0011 111 negative beginning disparity) in the serial data stream and realigns data on byte boundaries if required. When SYNCEN is low, serial input data is unframed in RD0–RD9.
SYNC/PASS	30	O	Synchronous detect. The SYNC output is asserted high upon detection of the comma pattern in the serial data path. SYNC pulses are output only when SYNCEN is activated (asserted high). In PRBS test mode (PRBSEN = high), SYNC/PASS outputs the status of the PRBS test results (high = pass).
TEST			
LOOPEN	15	I P/D ⁽²⁾	Loop enable. When LOOPEN is high (active), the internal loopback path is activated. The transmitted serial data is directly routed to the inputs of the receiver. This provides a self-test capability in conjunction with the protocol device. The TXP and TXN outputs are held in a high-impedance state during the loopback test. LOOPEN is held low during standard operational state with external serial outputs and inputs active.
PRBSEN	31	I P/D ⁽²⁾	PRBS enable. When PRBSEN is high, the PRBS generation circuitry is enabled. The PRBS verification circuit in the receive side is also enabled. A PRBS signal can be fed to the receive inputs and checked for errors, which are reported by the SYNC/PASS terminal indicating low.
ENABLE	1	I P/D ⁽¹⁾	When this terminal is low, the device is disabled for Iddq testing. RD0–RD9, RBCn, TXP and TXN are high-impedance. The pullup and pulldown resistors on any input are disabled. When ENABLE is high, the device operates normally.
POWER			
VDD	6, 16, 26	Supply	Digital logic power. Provides power for all digital circuitry and digital I/O buffers
VDDA	37	Supply	Analog power. VDDA provides power for the high-speed analog circuits, receiver, and transmitter.
VDDPLL	36	Supply	PLL power. Provides power for the PLL circuitry. This terminal requires additional filtering.
GROUND			
GNDA	35, 40	Ground	Analog ground. GNDA provides a ground for the high-speed analog circuits, RX and TX.
GNDQFN	PAD	Ground	Digital logic ground. Provides a ground for the logic circuits and digital I/O buffers

- (1) P/D = Internal pulldown resistor
 (1) P/U = Internal pullup resistor
 (2) P/D = Internal pulldown resistor

ABSOLUTE MAXIMUM RATINGS

over operating free-air temperature range (unless otherwise noted)

		VALUE ⁽¹⁾	UNIT
V _{DD}	Supply voltage ⁽²⁾	-0.3 to 3	V
V _I	Input voltage range at TTL terminals	-0.5 to 4	V
V _I	Input voltage range at other terminals	-0.3 to V _{DD} + 0.3	V
ESD	Electrostatic discharge	CDM: 1, HBM: 2	kV
T _{stg}	Storage temperature	-65 to 150	°C
T _A	Characterized free-air temperature range	-40 to 85	°C

- (1) Stresses beyond those listed under "absolute maximum ratings" may cause permanent damage to the device. These are stress ratings only, and functional operation of the device at these or any other conditions beyond those indicated under "recommended operating conditions" is not implied. Exposure to absolute-maximum-rated conditions for extended periods may affect device reliability.
- (2) All voltage values, except differential I/O bus voltages, are with respect to network ground terminal.

DISSIPATION RATINGS

PACKAGE	T _A ≤ 25°C POWER RATING	DERATING FACTOR ABOVE T _A = 25°C	T _A = 70°C POWER RATING	T _A = 85°C POWER RATING
RHA ⁽¹⁾⁽²⁾	2.85 W	28 mW/°C	1.57 W	1.4 W

- (1) The thermal resistance junction to ambient of the RHA package is 35°C/W measured on a high-K board.
- (2) The thermal resistance junction-to-case (exposed pad) of the RHA package is 5°C/W.

RECOMMENDED OPERATING CONDITIONS

over operating free-air temperature range (unless otherwise noted)

		MIN	NOM	MAX	UNIT
V _{DD} , V _{DDA} , V _{DDPLL}	Supply voltage	2.3	2.5	2.7	V
I _{DD} , I _{DDA} , I _{DDPLL}	Total supply current	Frequency = 1.25 Gbps, PRBS pattern; ENABLE = 1, V _{DD} , V _{DDPLL} and V _{DDA} = 2.7 V		113	mA
P _D	Total power dissipation	Frequency = 1.25 Gbps, PRBS pattern		235 305	mW
I _{DDQ}	Total shutdown current (I _{DD} +I _{DDA} + I _{DDPLL})	Enable = 0; V _{DD} , V _{DDPLL} and V _{DDA} = 2.7 V		1000	μA
PLL	Startup lock time	V _{DD} , V _{DDA} = 2.5 V		500	μs
T _A	Operating free-air temperature	-40		85	°C

REFERENCE CLOCK (REFCLK) TIMING REQUIREMENTS

over recommended operating conditions (unless otherwise noted)

PARAMETER	TEST CONDITIONS	MIN	TYP	MAX	UNIT
f	Frequency	Minimum data rate		TYP - 0.01% 60 TYP + 0.01%	MHz
		Maximum data rate		TYP - 0.01% 130 TYP + 0.01%	
	Accuracy	-100		100	ppm
DC	Duty cycle	40%	50%	60%	
	Jitter	Random plus deterministic		40	ps

TTL ELECTRICAL CHARACTERISTICS

over recommended operating conditions (unless otherwise noted)

PARAMETER	TEST CONDITIONS	MIN	TYP	MAX	UNIT
V _{OH} High-level output voltage	I _{OH} = -400 μA	V _{DD} - 0.2	2.3		V
V _{OL} Low-level output voltage	I _{OL} = 1 mA	GND	0.25	0.5	V
V _{IH} High-level input voltage		1.7		3.6	V
V _{IL} Low-level input voltage				0.8	V
I _{IH} High-level input current	V _{DD} = 2.3 V, V _{IN} = 2 V			40	μA
I _{IL} Low-level input current	V _{DD} = 2.3 V, V _{IN} = 0.4 V	-40			μA
C _{IN} Input capacitance				4	pF

TRANSMITTER/RECEIVER CHARACTERISTICS

over recommended operating conditions (unless otherwise noted)

PARAMETER	TEST CONDITIONS	MIN	TYP	MAX	UNIT
V _{OD} = TxD - TxN	R _t = 50 Ω	600	850	1100	mV
V _(CM) Transmit common mode voltage range	R _t = 50 Ω	1000	1250	1400	mV
Receiver input voltage requirement, V _{ID} = RxP - RxN		200		1600	mV
Receiver common mode voltage range, (RxP + RxN)/2		1000	1250	2250	mV
C _I Receiver input capacitance				2	pF
t _(TJ) Serial data total jitter (peak-to-peak)	Differential output jitter, random + deterministic, PRBS pattern, R _ω = 125 MHz			0.24	UI
t _(DJ) Serial data deterministic jitter (peak-to-peak)	Differential output jitter, PRBS pattern, R _ω = 125 MHz			0.12	UI
t _r , t _f Differential signal rise, fall time (20% to 80%)	R _L = 50 Ω, C _L = 5 pF, see Figure 6 and Figure 8	100		250	ps
Serial data jitter tolerance minimum required eye opening, (per IEEE-802.3 specification)	Differential input jitter, random + deterministic, R _ω = 125 MHz	0.25			UI
Receiver data acquisition lock time from power up				500	μs
Data relock time from application of valid input data stream	0.75 UI jitter closure with random data at 1.25 Gbps 0.20 UI jitter closure with 01010.. data at 1.25 Gbps			256 128	ns
t _{d(Tx latency)} Tx latency	See Figure 1	20		22	UI
t _{d(Rx latency)} Rx latency	See Figure 5 and Figure 7	18		24	UI

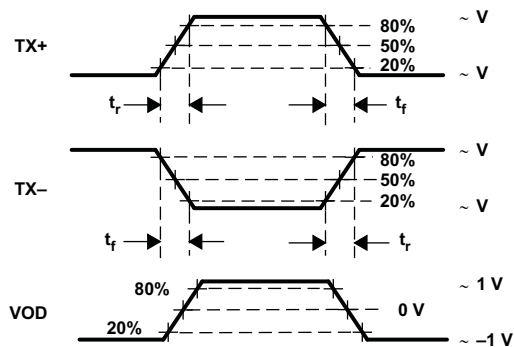

Figure 6. Differential and Common-Mode Output Voltage Definitions

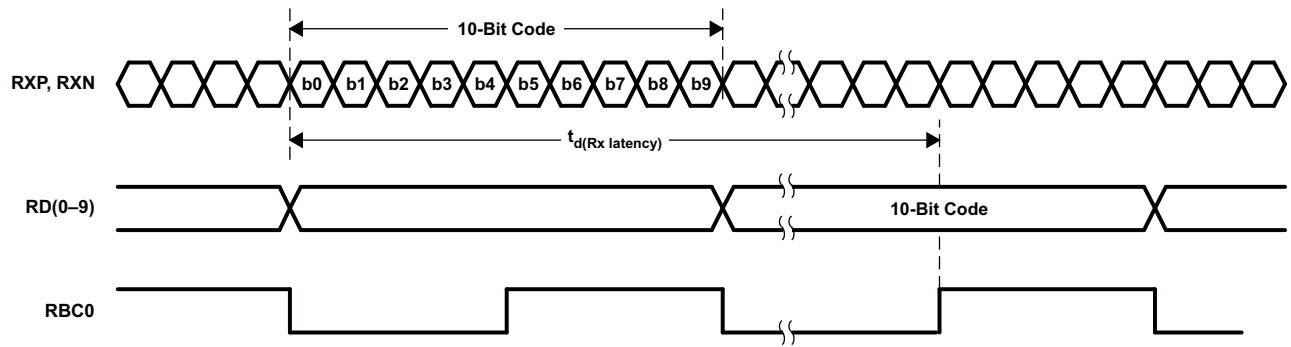

Figure 7. Receiver Latency, TBI Normal Mode Shown

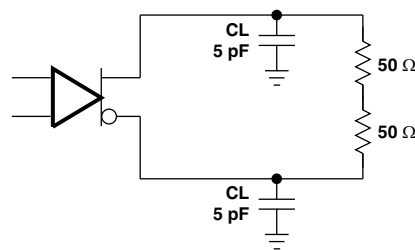

Figure 8. Transmitter Test Setup

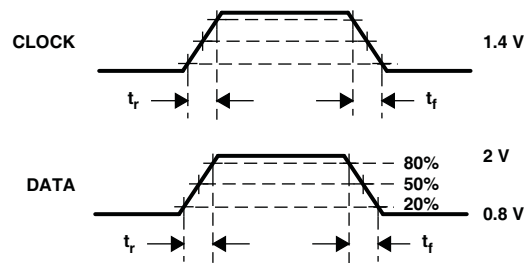

Figure 9. TTL Data I/O Valid Levels for AC Measurement

LVTTL OUTPUT SWITCHING CHARACTERISTICS

over recommended operating conditions (unless otherwise noted)

PARAMETER	TEST CONDITIONS	MIN	TYP	MAX	UNIT
$t_{r(RBC)}$ Clock rise time	80% to 20% output voltage, C = 5 pF (see Figure 9)	0.3		1.5	ns
$t_{f(RBC)}$ Clock fall time		0.3		1.5	ns
t_r Data rise time		0.3		1.5	ns
t_f Data fall time		0.3		1.5	ns
$t_{su(d1)}$ Data setup time (RD0–RD9)	TBI normal mode (see Figure 3), $R_w = 125$ MHz, data valid prior to RBC0 rising	2.5			ns
	TBI normal mode (see Figure 3), $R_w = 61.44$ MHz, data valid prior to RBC0 rising	5			ns
$t_{h(d1)}$ Data hold time (RD0–RD9)	TBI normal mode (see Figure 3), $R_w = 125$ MHz, data valid after RBC0 rising	2			ns
	TBI normal mode (see Figure 3), $R_w = 61.44$ MHz, data valid after RBC0 rising	4			ns
$t_{su(d3)}$ Data setup time (RD0–RD9)	TBI half-rate mode, $R_w = 125$ MHz (see Figure 2)	2.5			ns
$t_{h(d3)}$ Data hold time (RD0–RD9)	TBI half-rate mode, $R_w = 125$ MHz (see Figure 2)	1.5			ns

TRANSMITTER TIMING REQUIREMENTS

over recommended operating conditions (unless otherwise noted)

PARAMETER	TEST CONDITIONS	MIN	TYP	MAX	UNIT
$t_{su(d4)}$ Data setup time (TD0–TD9)		1.6			ns
$t_{h(d4)}$ Data hold time (TD0–TD9)		0.8			ns
t_r, t_f TD[0,9] data rise and fall time	See Figure 9			2	ns

Table 3. AVAILABLE OPTIONS

T_A	PACKAGE
	QFN PLASTIC QUAD FLAT PACK (RHA)
–40°C to 85°C	TLK1221RHA

APPLICATION INFORMATION

8b/10b Transmission Code

The PCS maps GMII signals into ten-bit code groups and vice versa, using an 8b/10b block coding scheme. The PCS uses the transmission code to improve the transmission characteristics of information to be transferred across the link. The encoding defined by the transmission code ensures that sufficient transitions are present in the PHY bit stream to make clock recovery possible in the receiver. Such encoding also greatly increases the likelihood of detecting any single- or multiple-bit errors that may occur during transmission and reception of information. The 8b/10b transmission code specified for use has a high transition density, is run length limited, and is dc-balanced. The transition density of the 8b/10b symbols ranges from 3 to 8 transitions per symbol. The definition of the 8b/10b transmission code is specified in IEEE 802.3 Gigabit Ethernet and ANSI X3.230-1994 (FC-PH), clause 11.

8b/10b transmission code uses letter notation describing the bits of an unencoded information octet. The bit notation of A, B, C, D, E, F, G, H for an unencoded information octet is used in the description of the 8b/10b transmission code-groups, where A is the LSB. Each valid code group has been given a name using the following convention: /Dx.y/ for the 256 valid data code-groups and /Kx.y/ for the special control code-groups, where y is the decimal value of bits EDCBA and x is the decimal value of bits HGF (noted as K<HGF.EDCBA>). Thus, an octet value of FE representing a code-group value of K30.7 would be represented in bit notation as 111 11110.

APPLICATION INFORMATION (continued)

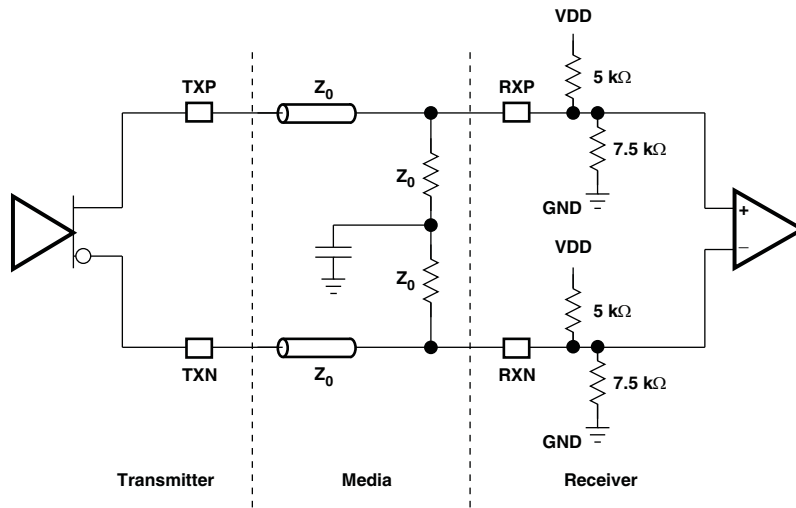

Figure 10. High-Speed I/O Directly Coupled Mode

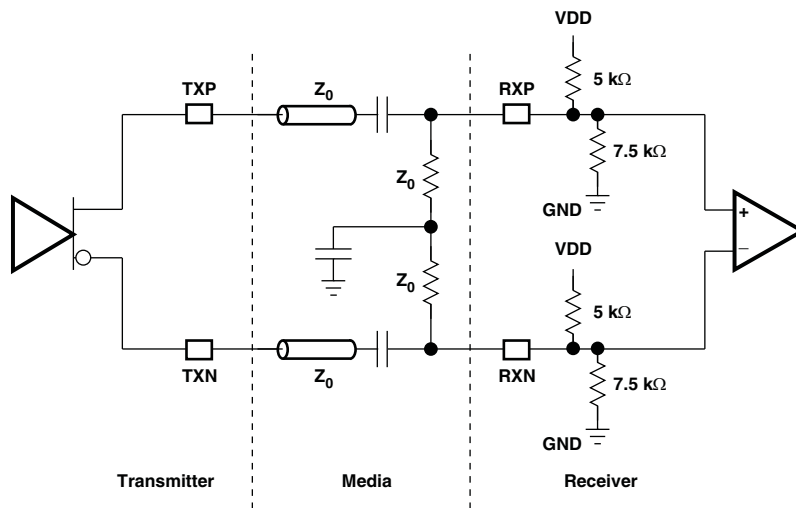

Figure 11. High-Speed I/O AC-Coupled Mode

APPLICATION INFORMATION (continued)

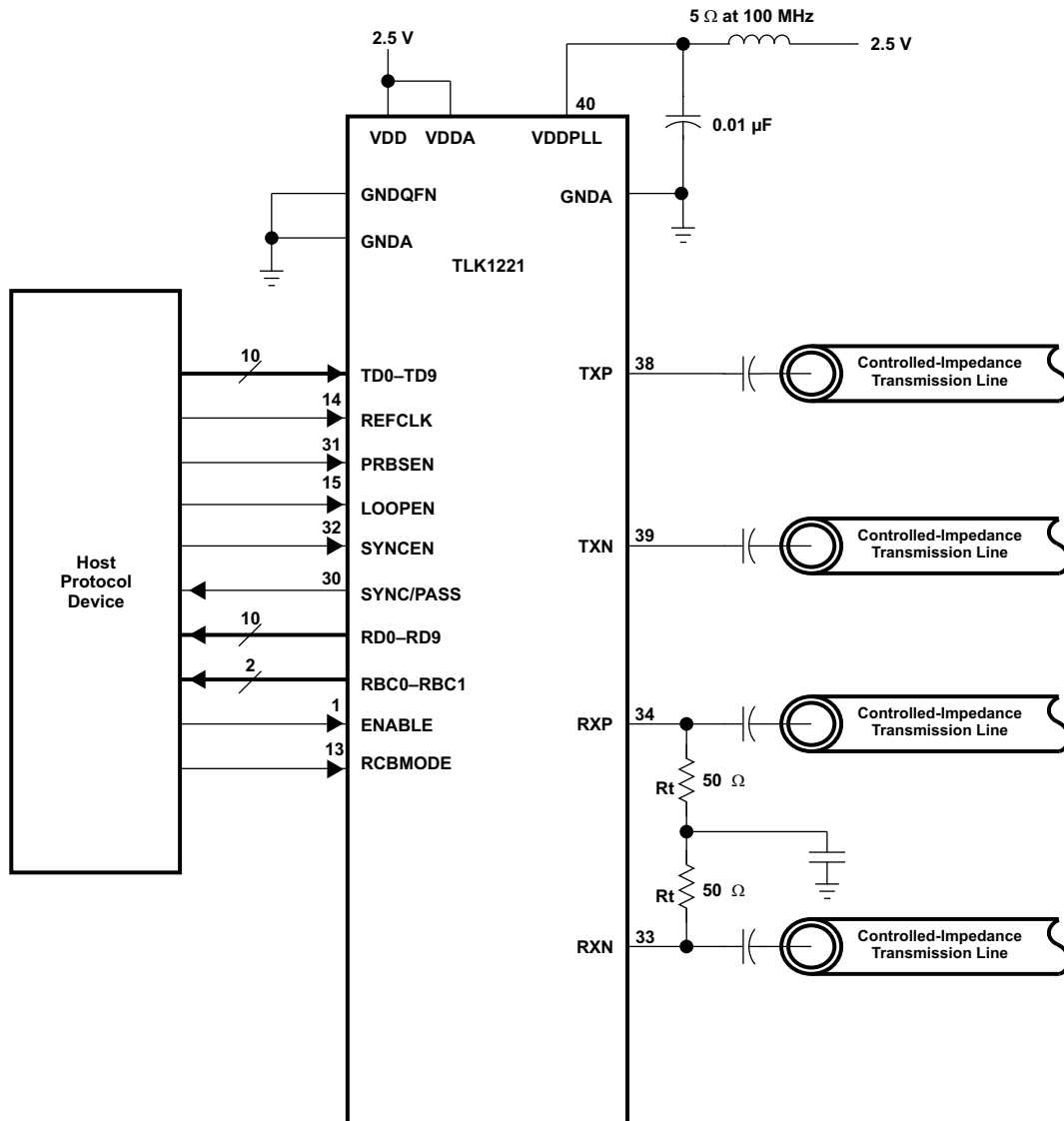

Figure 12. Typical Application Circuit (AC Mode)

PACKAGING INFORMATION

Orderable Device	Status ⁽¹⁾	Package Type	Package Drawing	Pins	Package Qty	Eco Plan ⁽²⁾	Lead/Ball Finish	MSL Peak Temp ⁽³⁾
TLK1221RHAR	ACTIVE	QFN	RHA	40	2500	Green (RoHS & no Sb/Br)	CU NIPDAU	Level-3-260C-168 HR
TLK1221RHARG4	ACTIVE	QFN	RHA	40	2500	Green (RoHS & no Sb/Br)	CU NIPDAU	Level-3-260C-168 HR
TLK1221RHAT	ACTIVE	QFN	RHA	40	250	Green (RoHS & no Sb/Br)	CU NIPDAU	Level-3-260C-168 HR
TLK1221RHATG4	ACTIVE	QFN	RHA	40	250	Green (RoHS & no Sb/Br)	CU NIPDAU	Level-3-260C-168 HR

⁽¹⁾ The marketing status values are defined as follows:

ACTIVE: Product device recommended for new designs.

LIFEBUY: TI has announced that the device will be discontinued, and a lifetime-buy period is in effect.

NRND: Not recommended for new designs. Device is in production to support existing customers, but TI does not recommend using this part in a new design.

PREVIEW: Device has been announced but is not in production. Samples may or may not be available.

OBSOLETE: TI has discontinued the production of the device.

⁽²⁾ Eco Plan - The planned eco-friendly classification: Pb-Free (RoHS), Pb-Free (RoHS Exempt), or Green (RoHS & no Sb/Br) - please check <http://www.ti.com/productcontent> for the latest availability information and additional product content details.

TBD: The Pb-Free/Green conversion plan has not been defined.

Pb-Free (RoHS): TI's terms "Lead-Free" or "Pb-Free" mean semiconductor products that are compatible with the current RoHS requirements for all 6 substances, including the requirement that lead not exceed 0.1% by weight in homogeneous materials. Where designed to be soldered at high temperatures, TI Pb-Free products are suitable for use in specified lead-free processes.

Pb-Free (RoHS Exempt): This component has a RoHS exemption for either 1) lead-based flip-chip solder bumps used between the die and package, or 2) lead-based die adhesive used between the die and leadframe. The component is otherwise considered Pb-Free (RoHS compatible) as defined above.

Green (RoHS & no Sb/Br): TI defines "Green" to mean Pb-Free (RoHS compatible), and free of Bromine (Br) and Antimony (Sb) based flame retardants (Br or Sb do not exceed 0.1% by weight in homogeneous material)

⁽³⁾ MSL, Peak Temp. -- The Moisture Sensitivity Level rating according to the JEDEC industry standard classifications, and peak solder temperature.

Important Information and Disclaimer:The information provided on this page represents TI's knowledge and belief as of the date that it is provided. TI bases its knowledge and belief on information provided by third parties, and makes no representation or warranty as to the accuracy of such information. Efforts are underway to better integrate information from third parties. TI has taken and continues to take reasonable steps to provide representative and accurate information but may not have conducted destructive testing or chemical analysis on incoming materials and chemicals. TI and TI suppliers consider certain information to be proprietary, and thus CAS numbers and other limited information may not be available for release.

In no event shall TI's liability arising out of such information exceed the total purchase price of the TI part(s) at issue in this document sold by TI to Customer on an annual basis.

TAPE AND REEL INFORMATION



QUADRANT ASSIGNMENTS FOR PIN 1 ORIENTATION IN TAPE



*All dimensions are nominal

Device	Package Type	Package Drawing	Pins	SPQ	Reel Diameter (mm)	Reel Width W1 (mm)	A0 (mm)	B0 (mm)	K0 (mm)	P1 (mm)	W (mm)	Pin1 Quadrant
TLK1221RHAR	QFN	RHA	40	2500	330.0	16.4	6.3	6.3	1.5	12.0	16.0	Q2
TLK1221RHAT	QFN	RHA	40	250	330.0	16.4	6.3	6.3	1.5	12.0	16.0	Q2

TAPE AND REEL BOX DIMENSIONS



*All dimensions are nominal

Device	Package Type	Package Drawing	Pins	SPQ	Length (mm)	Width (mm)	Height (mm)
TLK1221RHAR	QFN	RHA	40	2500	333.2	345.9	28.6
TLK1221RHAT	QFN	RHA	40	250	333.2	345.9	28.6

RHA (S-PQFP-N40)

PLASTIC QUAD FLATPACK

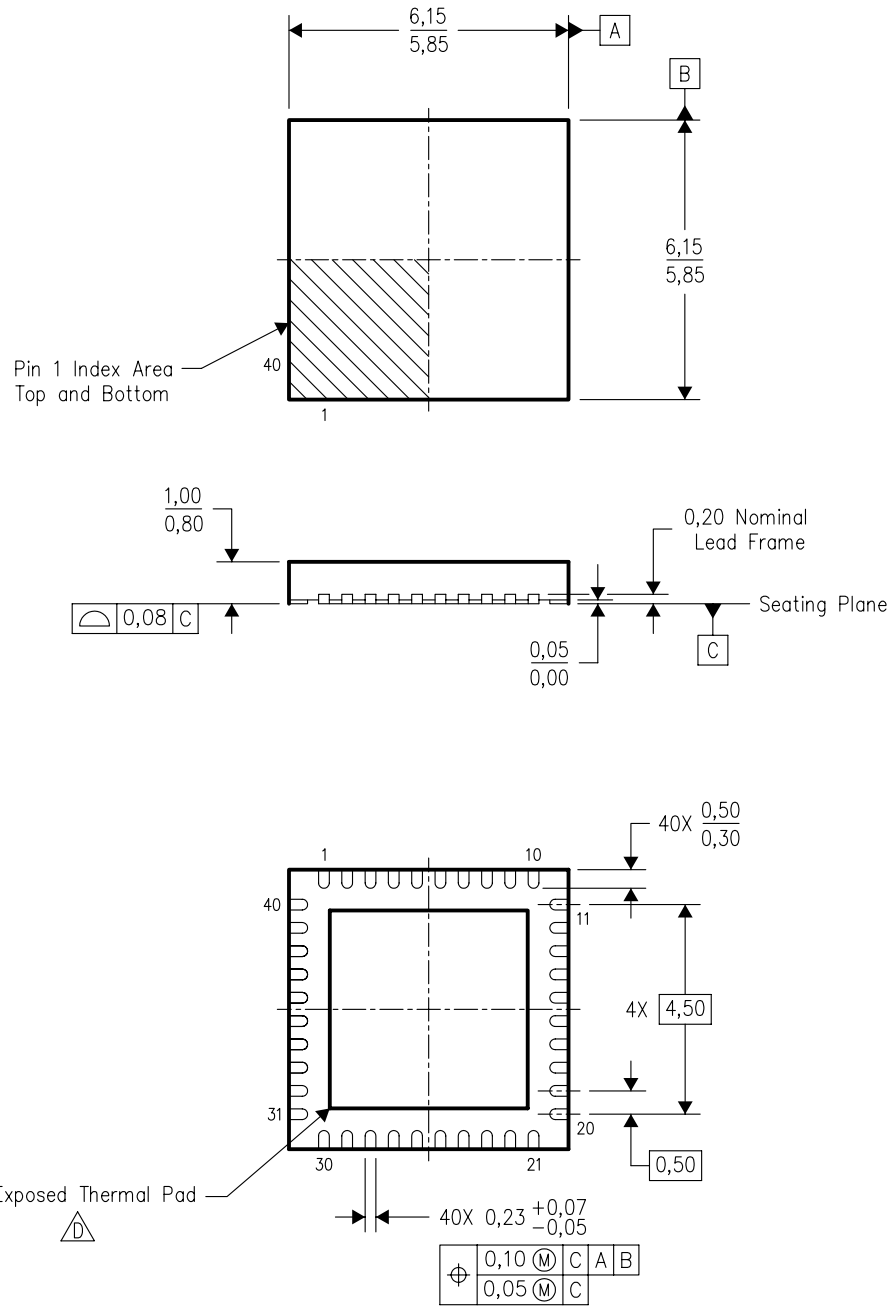

Bottom View

4204276/C 12/2004

- NOTES:
- A. All linear dimensions are in millimeters. Dimensioning and tolerancing per ASME Y14.5M-1994.
 - B. This drawing is subject to change without notice.
 - C. QFN (Quad Flatpack No-Lead) Package configuration.
 -  The package thermal pad must be soldered to the board for thermal and mechanical performance. See the Product Data Sheet for details regarding the exposed thermal pad dimensions.
 - E. Package complies to JEDEC MO-220 variation VJJD-2.

THERMAL INFORMATION

This package incorporates an exposed thermal pad that is designed to be attached directly to an external heatsink. The thermal pad must be soldered directly to the printed circuit board (PCB). After soldering, the PCB can be used as a heatsink. In addition, through the use of thermal vias, the thermal pad can be attached directly to the appropriate copper plane shown in the electrical schematic for the device, or alternatively, can be attached to a special heatsink structure designed into the PCB. This design optimizes the heat transfer from the integrated circuit (IC).

For information on the Quad Flatpack No-Lead (QFN) package and its advantages, refer to Application Report, QFN/SON PCB Attachment, Texas Instruments Literature No. SLUA271. This document is available at www.ti.com.

The exposed thermal pad dimensions for this package are shown in the following illustration.

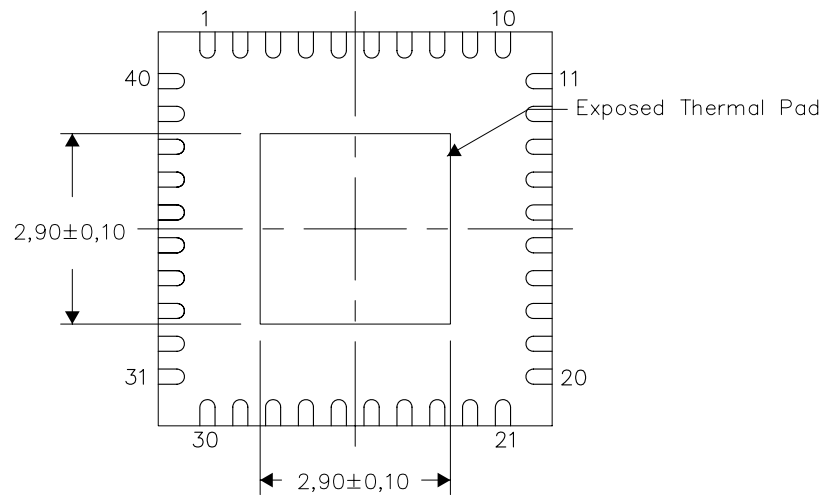

Bottom View

NOTE: All linear dimensions are in millimeters

Exposed Thermal Pad Dimensions

RHA (S-PQFP-N40)

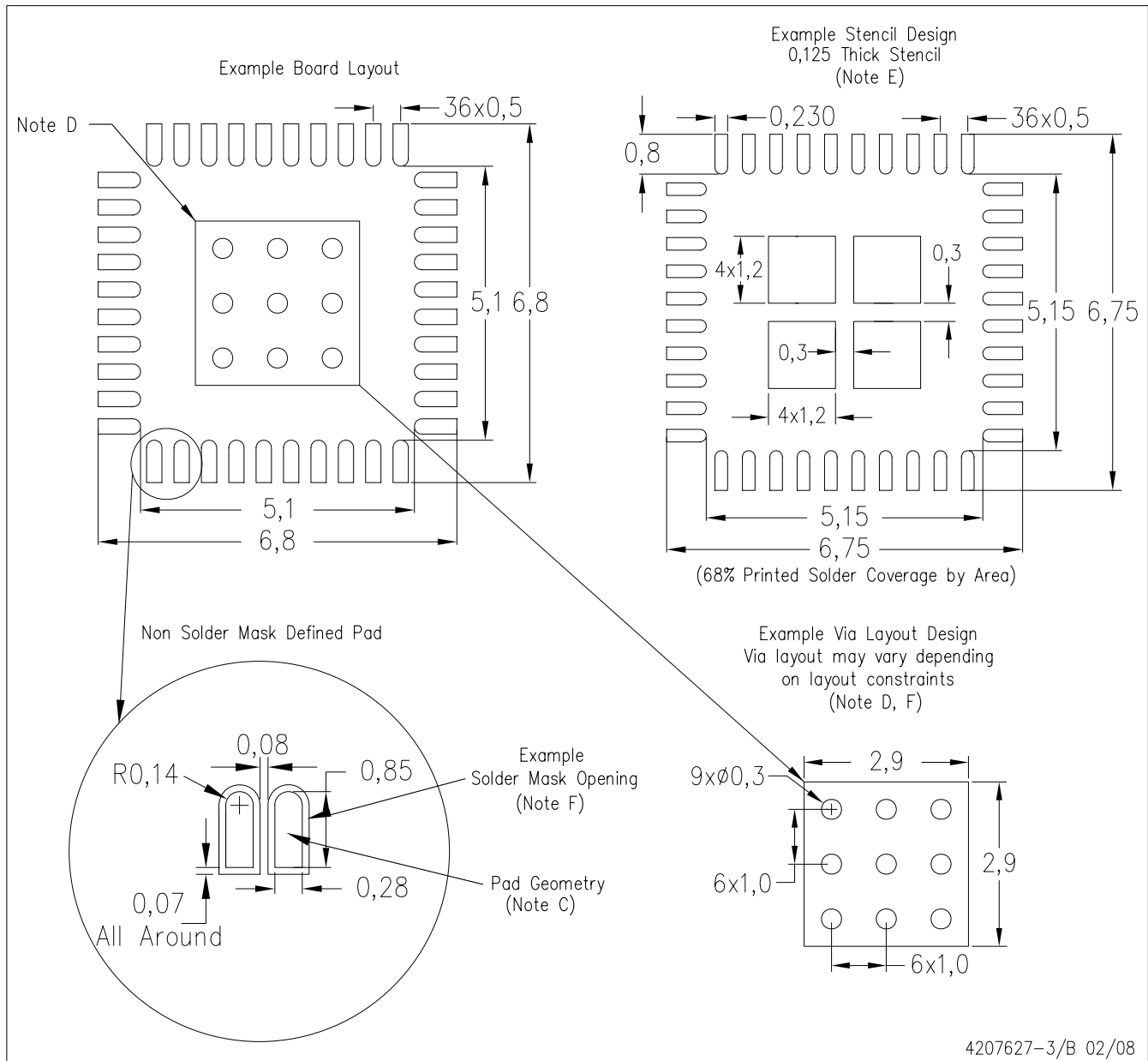

- NOTES:
- A. All linear dimensions are in millimeters.
 - B. This drawing is subject to change without notice.
 - C. Publication IPC-7351 is recommended for alternate designs.
 - D. This package is designed to be soldered to a thermal pad on the board. Refer to Application Note, Quad Flat-Pack Packages, Texas Instruments Literature No. SCBA017, SLUA271, and also the Product Data Sheets for specific thermal information, via requirements, and recommended board layout. These documents are available at www.ti.com <<http://www.ti.com>>.
 - E. Laser cutting apertures with trapezoidal walls and also rounding corners will offer better paste release. Customers should contact their board assembly site for stencil design recommendations. Refer to IPC 7525 for stencil design considerations.
 - F. Customers should contact their board fabrication site for recommended solder mask tolerances and via tenting recommendations for vias placed in the thermal pad.

IMPORTANT NOTICE

Texas Instruments Incorporated and its subsidiaries (TI) reserve the right to make corrections, modifications, enhancements, improvements, and other changes to its products and services at any time and to discontinue any product or service without notice. Customers should obtain the latest relevant information before placing orders and should verify that such information is current and complete. All products are sold subject to TI's terms and conditions of sale supplied at the time of order acknowledgment.

TI warrants performance of its hardware products to the specifications applicable at the time of sale in accordance with TI's standard warranty. Testing and other quality control techniques are used to the extent TI deems necessary to support this warranty. Except where mandated by government requirements, testing of all parameters of each product is not necessarily performed.

TI assumes no liability for applications assistance or customer product design. Customers are responsible for their products and applications using TI components. To minimize the risks associated with customer products and applications, customers should provide adequate design and operating safeguards.

TI does not warrant or represent that any license, either express or implied, is granted under any TI patent right, copyright, mask work right, or other TI intellectual property right relating to any combination, machine, or process in which TI products or services are used. Information published by TI regarding third-party products or services does not constitute a license from TI to use such products or services or a warranty or endorsement thereof. Use of such information may require a license from a third party under the patents or other intellectual property of the third party, or a license from TI under the patents or other intellectual property of TI.

Reproduction of TI information in TI data books or data sheets is permissible only if reproduction is without alteration and is accompanied by all associated warranties, conditions, limitations, and notices. Reproduction of this information with alteration is an unfair and deceptive business practice. TI is not responsible or liable for such altered documentation. Information of third parties may be subject to additional restrictions.

Resale of TI products or services with statements different from or beyond the parameters stated by TI for that product or service voids all express and any implied warranties for the associated TI product or service and is an unfair and deceptive business practice. TI is not responsible or liable for any such statements.

TI products are not authorized for use in safety-critical applications (such as life support) where a failure of the TI product would reasonably be expected to cause severe personal injury or death, unless officers of the parties have executed an agreement specifically governing such use. Buyers represent that they have all necessary expertise in the safety and regulatory ramifications of their applications, and acknowledge and agree that they are solely responsible for all legal, regulatory and safety-related requirements concerning their products and any use of TI products in such safety-critical applications, notwithstanding any applications-related information or support that may be provided by TI. Further, Buyers must fully indemnify TI and its representatives against any damages arising out of the use of TI products in such safety-critical applications.

TI products are neither designed nor intended for use in military/aerospace applications or environments unless the TI products are specifically designated by TI as military-grade or "enhanced plastic." Only products designated by TI as military-grade meet military specifications. Buyers acknowledge and agree that any such use of TI products which TI has not designated as military-grade is solely at the Buyer's risk, and that they are solely responsible for compliance with all legal and regulatory requirements in connection with such use.

TI products are neither designed nor intended for use in automotive applications or environments unless the specific TI products are designated by TI as compliant with ISO/TS 16949 requirements. Buyers acknowledge and agree that, if they use any non-designated products in automotive applications, TI will not be responsible for any failure to meet such requirements.

Following are URLs where you can obtain information on other Texas Instruments products and application solutions:

Products

Amplifiers	amplifier.ti.com
Data Converters	dataconverter.ti.com
DSP	dsp.ti.com
Clocks and Timers	www.ti.com/clocks
Interface	interface.ti.com
Logic	logic.ti.com
Power Mgmt	power.ti.com
Microcontrollers	microcontroller.ti.com
RFID	www.ti-rfid.com
RF/IF and ZigBee® Solutions	www.ti.com/lprf

Applications

Audio	www.ti.com/audio
Automotive	www.ti.com/automotive
Broadband	www.ti.com/broadband
Digital Control	www.ti.com/digitalcontrol
Medical	www.ti.com/medical
Military	www.ti.com/military
Optical Networking	www.ti.com/opticalnetwork
Security	www.ti.com/security
Telephony	www.ti.com/telephony
Video & Imaging	www.ti.com/video
Wireless	www.ti.com/wireless

Mailing Address: Texas Instruments, Post Office Box 655303, Dallas, Texas 75265
Copyright © 2008, Texas Instruments Incorporated